



# MANUAL

## DMK 351

### Low Pressure Transmitter with Ceramic Diaphragm



- For measurement small system pressure and filling heights
- Ranges from 4 kPa to 2 MPa
- Accuracy 0.35 %, 0.5 % (1 %, 0.25 %)
- For mediums compatible with stainless steel 1.4404, PP, PVDF, ceramic  $Al_2O_3$  in combination with Viton or EPDM
- High resistance to overload, temperature and medium
- Optional intrinsically safe version
  -  II 1 G Ex ia IIC T4 Ga,
  -  II 1 G Ex ia IIC T6 Ga,
  -  II 1 D Ex ia IIIC T85°C Da

## Contents

<b>1. General instructions and information</b> .....	<b>3</b>
1.1 Symbols used.....	3
1.2 Safety warnings and cautions.....	3
1.3 Scope of delivery.....	3
1.4 Description of the delivery and packing.....	3
1.5 Storage.....	3
1.6 Installation and commissioning.....	3
1.7 Spare parts.....	3
1.8 Repairs.....	3
1.9 Warranty.....	3
<b>2. End of service and disposal</b> .....	<b>3</b>
2.1 End of service.....	3
2.2 Disposal.....	3
<b>3. Product description</b> .....	<b>4</b>
3.1 Application.....	4
3.2 Description.....	4
3.3 Dimensional drawings.....	4
<b>4. Installation, operation and maintenance</b> .....	<b>5</b>
4.1 Installation and commissioning.....	5
4.2 Operation and maintenance.....	5
4.3 Error handling.....	6
<b>5. Product specifications</b> .....	<b>7</b>
5.1 Technical specifications.....	7
5.2 Supplementary specifications.....	7
5.3 Operation conditions.....	7
5.4 Other data.....	7
<b>6. Ordering information</b> .....	<b>8</b>
6.1 Ordering table.....	8

## 1. General instructions and information

### 1.1 Symbols used



Symbol of warning; for safe use it is necessary to proceed according to the instructions



Symbol CE certifies compliance of the product with the respective government directives



Symbol of "Output"



Symbol of "Supply"



This product does not belong to public waste and it is subjected to separate collection

### 1.2 Safety warnings and cautions



The equipment shall be supplied from a safe voltage source that meets all requirements of the standard EN 61010-1 and must be installed in compliance with national requirements and standards providing safety.

The equipment may only be installed by a qualified personnel who are familiar with national and international laws, directives, standards and with the instructions manual. The instrument may not be used for other purposes than as specified in this instruction manual.

For elimination of a risk of injury from electric shock or fire the maximum operational parameters of the instrument may not be exceeded, particularly range of operating temperature because of exposure to heat from connected or surrounding technological equipment must not be exceeded!

The equipment should be installed in suitable environment without any direct sunlight, occurrence of dust, high temperatures, mechanical vibrations and shocks and protected against rain and excessive moisture.

### 1.3 Scope of delivery

With the product is delivered:

- Manual for installation, operation and maintenance
- Certificate of calibration (only with calibrated sensors)

### 1.4 Description of the delivery and packing

The product is packaged in a protective cover and provided with an identification label with a mark of the output control.

The product must not be exposed to direct rain, vibrations and shocks during transport.

### 1.5 Storage

Store the instrument in dry rooms at temperatures from -40 to +100 °C without condensation of water vapours.

### 1.6 Installation and commissioning

During installation, commissioning, operation and maintenance follow the instructions in chapter 4.

### 1.7 Spare parts

Any of the compact parts of the product can be also ordered as a spare part if there are not required special procedures or technological operations for the exchange.

## 1.8 Repairs

Products are repaired by the manufacturer. The products for repair should be sent together with description of the fault or defect in a packing that guarantees damping of shocks and vibrations and protects against damage during transport.

## 1.9 Warranty

Products are covered by a warranty for a period of 24 months from the delivery date on the delivery note. The manufacturer guarantees technical and operational parameters of the products within scope of the applicable documentation. Warranty period is specified with individual items and begins from the day of takeover of the goods by the purchaser or delivery to the carrier. Any claims concerning to defects of the goods together can be filed with the seller within the warranty period and the claimed product shall be presented. The claiming party shall give identification of the product, number of the delivery note and description of the fault or defect.

The manufacturer is not responsible for any defects caused by improper storage, incorrect connection, damages caused by external effects, in particular by effects of factors with excessive values, unqualified installation, improper operation or common wearing.

## 2. End of service and disposal

### 2.1 End of service

Dismounting and disposal of the device is possible after disconnecting of power supply.

### 2.2 Disposal



The products do not contain any environmentally hazardous parts. When disposing the packing and destroyed or irreparably damaged product proceed according to the local regulations.

### 3. Product description

## DMK 351 Low pressure transmitter with ceramic diaphragm

- For measurement small system pressure and filling heights
- Ranges from 4 kPa to 2 MPa
- Accuracy 0.35 %, 0.5 % (1 %, 0.25 %)
- For mediums compatible with stainless steel 1.4404, PP, PVDF, ceramic Al<sub>2</sub>O<sub>3</sub> in combination with Viton or EPDM
- High resistance to overload, temperature and medium
- Optional intrinsically safe version
  - ⊕ II 1 G Ex ia IIC T4 Ga,
  - ⊕ II 1 G Ex ia IIC T6 Ga,
  - ⊕ II 1 D Ex ia IIIC T85°C Da



### 3.1 Application

DMK 351 pressure transmitters are designed for low system pressure and fill heights measurement. Their main application is in plant and machine engineering as well as laboratory techniques.

### 3.2 Description

The devices convert pressure of liquids to an electric signal. Their ranges are 4 kPa to 2 MPa. The devices can be used for all pressure mediums compatible with stainless steel 1.4404, PP, PVDF, Al<sub>2</sub>O<sub>3</sub> ceramic in combination with Viton or EPDM. When the pressure transmitter is exposed to pressure, it provides output signal. Signal is also magnified and standardized by built-in electronics. The sensor and the electronic unit are built-in the stainless steel bushing in such a way that the pressure transmitter is highly resistant against shock and vibration. The pressure connector consists of a thread with an input port, the electrical connection consists of a connector or a cable. Sensors are characterized by small dimensions.

### 3.3 Dimensional drawings

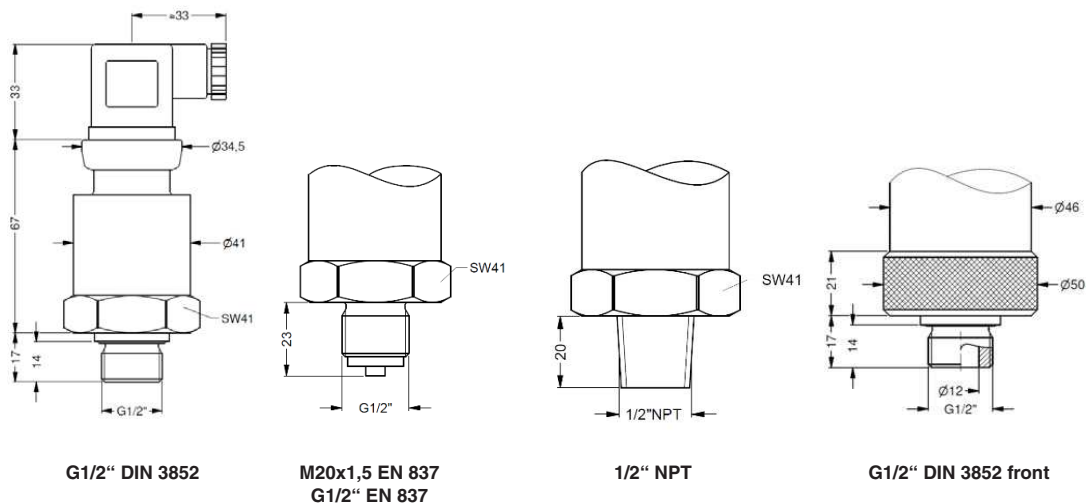

## 4. Installation, operation and maintenance

### 4.1 Installation and commissioning

#### 4.1.1 General information

- \* Install the device only when depressurized and currentless!
- \* Handle this high-sensitive electronic precision measuring device with care to prevent damage of the device.
- \* To avoid damaging the diaphragm, remove protective cap (if delivered) directly before starting assembly.
- \* The protective cap has to be stored! Place the protective cap on the pressure port again immediately after disassembling.
- \* Handle the unprotected diaphragm very carefully - it is very sensitive and may be easily damaged.
- \* After installation and proper connection, check the tightness of pressure connections.
- \* When measuring small gauge pressures, use an electric cable with interconnecting capillary tube to supply correct reference pressure.
- \* Device is put into operation by switching on the power supply.

#### 4.1.2 Special information

- \* Take note that no assembly stress occurs at the pressure connection, since this may cause a shifting of the characteristic curve. This is especially important for very small pressure ranges.
- \* If there is any danger of damage by lightning or overpressure when the device is installed outdoor, we suggest putting a sufficiently dimensioned overpressure or overvoltage protection between the supply or switch cabinet and the device.
- \* For outdoor and damp areas installations follow these instructions:
  - Choose an assembly position, which allows the flow-off of splashed water and condensation.
  - Avoid permanent fluid at sealing surfaces!
  - When using a cable outlet device, turn the outgoing cable downwards. If the cable has to be turned upwards, then point it downward so the moisture can drain.
  - Install the device in such way that it is protected from direct solar irradiation. Adverse conditions can cause that the permissible operating temperature can be overstepped and the operability of the device can be affected or damaged. In addition, if the internal pressure increases due to solar irradiation, temporary measurement errors may be caused.
- \* For devices for gauge pressure with gauge reference (small hole next to the electrical connection), take note to:
  - Check and verify if the IP protection is sufficient for the intended environment.
  - Install the device in such a way, that the gauge reference necessary for the correct measurement of gauge pressure (small hole next to the electrical connection) is protected from dirt and moisture. If the gauge reference is clogged by liquid or dirt, the device will not function properly and will not measure precisely. Furthermore, getting moisture inside the sensor can lead to permanent damage of the device.



If there is probably contact of the gauge pressure sensor with occasional liquid splashes, for electrical connection we recommend to use cable outlet and cable with air tube (IP 67). This adjustment can be done by JSP, s.r.o.

#### 4.1.3 Installation steps

Follow detailed instructions according to specific pressure connection below:

##### Installation steps for DIN 3852

DO NOT USE ANY ADDITIONAL SEALING MATERIALS, LIKE YARN, HEMP OR TEFLON TAPE!

- \* Check to ensure the proper groove fitting of the o-ring and additionally to ensure no damage to the o-ring.
- \* Ensure that the sealing surface of the taking part is perfectly smooth and clean.
- \* Screw the device into the corresponding thread by hand.
- \* If you have a device with a knurled ring, the transmitter has to be screwed in by hand only.
- \* Devices with a spanner flat have to be tightened with an open-end wrench (G1/2": approx. 10 Nm).

##### Installation steps for EN 837

- \* Use a suitable seal, corresponding to the medium and the pressure input (e. g. a cooper gasket). Sealing is not part of the supply.
- \* Ensure that the sealing surface of the taking part is perfectly smooth and clean.
- \* Screw the device into the corresponding thread by hand.
- \* Tighten it with a wrench (G1/2" and M20x1.5: approx. 50 Nm).

##### Installation steps for NPT

- \* Use a suitable seal (e. g. a PTFE-strip).
- \* Screw the device into the corresponding thread by hand.
- \* Tighten it with a wrench (1/2" NPT: approx. 70 Nm).



When both connections of threaded parts are made of stainless steel, there is danger of galling (formation of cold weld). This can also occur during ordinary screwing by hand without using tightening key. If the cold weld is made, the thread is then damaged and parts are unusable. Before first screwing, it is therefore necessary to check whether threads are free of impurities (and clean if needed) and then treat the threads against galling (formation of cold weld) by appropriate lubricant. For example use paste G-Rapid plus or Lukosan M11 (in case of connection for oxygen). For tapered threads is usually used Teflon tape.

#### 4.1.4 Electrical connection

See the following figure.

### 4.2 Operation and maintenance

The device is maintenance free. In case of the contamination clean the pressure connection regularly and clean it regardless to medium and contamination. Do not use aggressive cleaning solvents. Do not use pressurized water.

**Electrical connections**

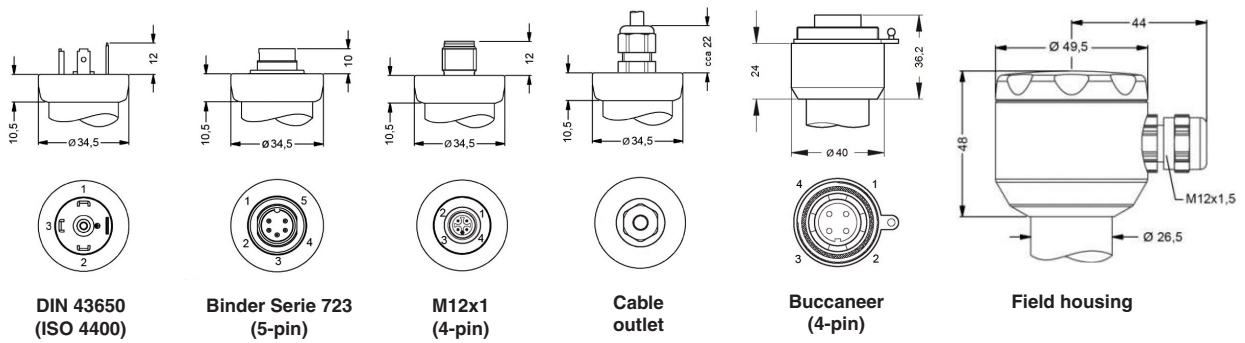

**Pin configuration:**

Connection	ISO 4400 (DIN 43650)	Binder 723 5-pin	M12x1 4-pin	Buccaneer 4-pin	Field housing	Wire colors (DIN 47100)
<b>2-wire:</b>						
Supply +	1	3	1	1	IN+	White
Supply -	2	4	2	2	IN-	Brown
Grounding	⊥	5	4	4	⊥	Yellow-green
<b>3-wire:</b>						
Supply +	1	3	1	1	IN+	White
Supply -	2	4	2	2	IN-	Brown
Signal +	3	1	3	3	OUT+	Green
Grounding	⊥	5	4	4	⊥	Yellow-green

**2-wire connection  
(current):**

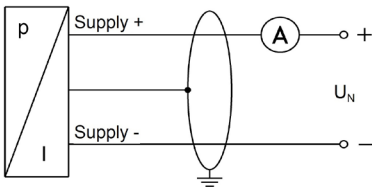

**3-wire connection  
(voltage):**

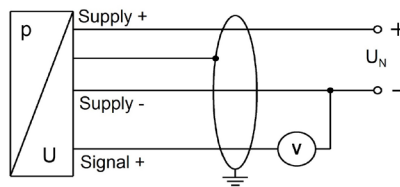

**4.3 Error handling**

Malfunction	Possible cause	Error detection / corrective
no output signal	faulty connection	inspect the connection
	line break	inspect all line connections necessary to supply the device (including the connector plugs)
	defective amperemeter (signal input)	inspect the amperemeter (fuse) or the analogue input of the PLC
analogue output signal too low	load resistance too high	verify the value of the load resistance
	supply voltage too low	verify the output voltage of the power supply
	defective energy supply	inspect the power supply and the applied supply voltage at the device
small shift of output signal	diaphragm is highly contaminated	careful cleaning with non-aggressive cleaning solution and a soft brush or sponge; incorrect cleaning can cause irreparable damages on diaphragm or seals
	diaphragm is calcified or coated with deposit	if possible, it is recommended to send the device to JSP, s.r.o. for decalcification or cleaning
large shift of output signal	diaphragm is damaged (caused by overpressure or manually)	check the diaphragm; if it is damaged, please send the device to JSP, s.r.o. for repair
wrong or no output signal	manually, thermally or chemically damaged cable	check the cable; a possible consequence of a damaged cable is pitting corrosion on the stainless steel housing; if you determine this please return the device to JSP, s.r.o. for repair

## 5. Product specifications

### 5.1 Technical specifications

**Application:**

liquids

**Measuring principle:**

capacitive

**Ranges and overload capacity:**

see ordering table

**Output signal:**

current 4 to 20 mA (2-wire)

voltage 0 to 10 V (3-wire)

**Supply voltage:**

$U_N = 9$  to 32 VDC (2-wire)

$U_N = 12.5$  to 32 VDC (3-wire)

intrinsically safe version

$U_N = 14$  to 28 VDC / 93 mA

**Load resistance:**

$R_{max} = [(U_N - U_{Nmin}) / 0.02 \text{ A}] \Omega$  (2-wire, current)

$R_{min} = 10 \text{ k}\Omega$  (3-wire, voltage)

**Accuracy:**

$\leq \pm 1 \%$  HMR

$\leq \pm 0.5 \%$  HMR

$\leq \pm 0.35 \%$  HMR

$\leq \pm 0.25 \%$  HMR

**Long term stability:**

$\leq \pm 0.1 \%$  HMR / year at reference conditions

**Response time:**

$\leq 200 \text{ ms}$  (mean)

$\leq 380 \text{ ms}$  (maximal)

### 5.2 Supplementary specifications

**Effect of temperature changes:**

$\leq \pm 0.1 \%$  HMR / 10 K

(in compensated range -20 to +80 °C)

**Influence effects - load:**

$\leq 0.05 \%$  HMR / k $\Omega$

**Influence effects - supply:**

$\leq 0.05 \%$  HMR / 10 V

**EMC (Electromagnetic compatibility):**

emission and immunity according to EN 61326

**Short-circuit protection:**

permanent

**Reverse polarity protection:**

no damage, but also no function

**Current consumption:**

signal output current max. 21 mA

signal output voltage max. 5 mA

**Operational life:**

> 100 million pressure cycles

### 5.3 Operation conditions

**Permissible temperatures:**

medium temperature -40 to +125 °C

environment temperature -40 to +85 °C

(Ex version: zone 0: -20 to +60 °C

zone 1 or higher: -25 to +70 °C)

for T6: -25 to 60 °C)

**Storage temperature:**

-40 to +100 °C

**Installation position:**

selectable

**Mechanical resistance:**

vibration 10 g RMS (20 to 2000 Hz)

according to DIN EN 60068-2-6

shock 100 g / 1 ms

according to DIN EN 60068-2-27

### 5.4 Other data

**Housing:** IP 65, IP 67, IP 68

**Weight:** approx. 200 g

**Materials:**

pressure port - stainless steel 1.4404

(option PP, PVDF)

housing - stainless steel 1.4404

(option PP, PVDF)

(compact field housing - 1.4301 (304),

with cable gland M12x1.5, brass, nickel plated)

seal - Viton (FKM), EPDM

diaphragm - ceramic  $\text{Al}_2\text{O}_3$  96 % (99,9 %)

media wetted parts - pressure port, seal, diaphragm

**Pressure connections:**

G1/2" DIN 3852

M20x1.5 EN 837-1/-3

G1/2" EN 837-1/-3

1/2" NPT

G1/2" DIN 3852 open port (PN  $\leq$  10 bar)

**Electrical connections:**

*standard*

ISO 4400 (DIN 43650) connector (IP 65)

*option*

Binder Serie 723 connector, 5-pin (IP 67)

PG 7 cable outlet with cable 2 m (IP 67)

Buccaneer connector (IP 68)

ISO 4400 (DIN 43650) connector (IP 67)

M12x1, 4-pin, Binder 713 (IP 67)

compact field housing (IP 67)

HMR ... upper range limit



## 6. Ordering information

### 6.1 Ordering table

Type	Description	
DMK 351 290	Gauge pressure transmitter (in kPa)	
DMK 351 291	Absolute pressure transmitter (in kPa)	
DMK 351 292	Level transmitter (in m H <sub>2</sub> O)	
Code	Range	Overload capacity
0400	0 to 4 kPa (0 to 0.4 m H <sub>2</sub> O)	200 kPa
0600	0 to 6 kPa (0 to 0.6 m H <sub>2</sub> O)	200 kPa
1000	0 to 10 kPa (0 to 1 m H <sub>2</sub> O)	400 kPa
1600	0 to 16 kPa (0 to 1.6 m H <sub>2</sub> O)	400 kPa
2500	0 to 25 kPa (0 to 2.5 m H <sub>2</sub> O)	600 kPa
4000	0 to 40 kPa (0 to 4 m H <sub>2</sub> O)	600 kPa
6000	0 to 60 kPa (0 to 6 m H <sub>2</sub> O)	800 kPa
1001	0 to 100 kPa (0 to 10 m H <sub>2</sub> O)	800 kPa
1601	0 to 160 kPa (0 to 16 m H <sub>2</sub> O)	1.5 MPa
2501	0 to 250 kPa (0 to 25 m H <sub>2</sub> O)	2.5 MPa
4001	0 to 400 kPa (0 to 40 m H <sub>2</sub> O)	2.5 MPa
6001	0 to 600 kPa (0 to 60 m H <sub>2</sub> O)	3.5 MPa
1002	0 to 1 MPa (0 to 100 m H <sub>2</sub> O)	3.5 MPa
1602	0 to 1.6 MPa (0 to 160 m H <sub>2</sub> O)	4.5 MPa
2002	0 to 2 MPa (0 to 200 m H <sub>2</sub> O)	4.5 MPa
9999	Other range	
Code	Output signal	
1	4 to 20 mA / 2-wire	
3	0 to 10 V / 3-wire	
E	4 to 20 mA / 2-wire, intrinsic safety version Ex ia	
N	4 to 20 mA / 2-wire, type of protection „n“, (Ex) II 3 G Ex nA IIC T4 Gc (only for connector 105, E05)	
9	Other	
Code	Accuracy	
8	1 % (for non-standard ranges)	
5	0.5 %	
3	0.35 % (standard)	
2	0.25 % (on request)	
U	1 %, with certificate of calibration (for non-standard ranges)	
T	0.5 %, with certificate of calibration	
S	0.35 %, with certificate of calibration	
R	0.25 % (on request), with certificate of calibration	
N	Table of measured values for accuracy 0.5 %	
M	Table of measured values for accuracy 0.35 %	
9	Other	
Code	Electrical connection	
100	ISO 4400 (DIN 43650) connector (IP 65)	
105	ISO 4400 (DIN 43650) connector (IP 65) + silicone sealant (only for Ex nA)	
200	Binder Serie 723 connector, 5-pin (IP 67)	
400	PG 7 cable outlet / cable 2 m (other cable lengths consult with supplier)	
500	Buccaneer connector (IP 68)	
800	Field housing, stainless steel (IP 67)	
E00	ISO 4400 (DIN 43650) connector (IP 67)	
E05	ISO 4400 (DIN 43650) connector (IP 67) + silicone sealant (only for Ex nA)	
M00	M12x1 connector, 4-pin, Binder 713 (IP 67)	
999	Other	
Code	Pressure connection	
100	G1/2" DIN 3852	
200	G1/2" EN 837-1/-3 (manometric)	
800	M20x1.5 EN 837-1/-3 (manometric)	
N00	1/2" NPT	
H00	G1/2" DIN 3852 open port (PN <= 10 bar)	
999	Other	
Code	Seal	
1	Viton (FKM)	
3	EPDM	
9	Other	
Code	Pressure connection material	
1	Stainless steel 1.4404	
E	PP (only G1/2" DIN 3852 open port H00)	
B	PVDF (only G1/2" DIN 3852 open port H00)	
9	Other	
Code	Optional accessories	
2	Ceramics Al <sub>2</sub> O <sub>3</sub> 96 %	
C	Ceramics Al <sub>2</sub> O <sub>3</sub> 99,9 % (only for 10 kPa <= PN <= 100 kPa) (on request)	
9	Other	
Code	Optional accessories	
000	Standard version	
999	Other	
For code U	Certificate of calibration	
For code T	Certificate of calibration	
For code S	Certificate of calibration	
For code R	Certificate of calibration	

Example of order: DMK 351 290 - 0400 - 1 - 3 - 100 - 100 - 1 - 1 - 2 - 000





## **JSP Industrial Controls**

**JSP, s.r.o.** | Raisova 547, 506 01 Jičín, Czech Republic  
+420 493 760 811 | [export@jsp.cz](mailto:export@jsp.cz) | [www.jsp.cz](http://www.jsp.cz)

**Your Supplier:**